



Product Specification Sheet

Model: ET-152 Flyable 2-Way Loudspeaker System



Series	Versatile Flyable & Portable
Application	Portable & Permanent Installation. The ET-152 should be used whenever high intelligibility & maximum pattern control is needed for speech & music sound reinforcement.
Type	Flyable High Output Loudspeaker System.
Configuration	2-Way (Passive, Full-Range)
LF	15" cast frame w/ 2.5" voice coil
HF	1" exit w/ 2" voice coil, Titanium diaphragm
Dispersion	60° (H) x 50° (V) elliptical horn
Horn Options	
Freq. Response	55 Hz – 16 kHz
Power	400 Watts RMS
SPL	103 dB @ 1 W / 1 M (2.83V @ 1M)
Impedance	8 Ω nominal
Crossover Freq.	2.2 kHz
Input	NL4, Barrier Strip, or ¼" jack
Fly-Points	(12) 3 on top; 3 on bottom, 2 on each side, 2 on rear (3/8" x 16)
Construction	¾" void free birch veneer plywood. Top and side panels internally reinforced with "steel" angle brackets making the cabinet structurally engineered for flying. All joints are reinforced with internal wood bracing both glued and cross-nailed in place.
Finish	The enclosure will have the deliverable finish options of "unfinished" (for future staining), "black textured enamel paint", or "white textured enamel paint". Our "ROADCOAT" Touring Finish is available for a nominal up-charge.
Grille	16 Gauge Perforated Steel (in White or Black)
Avail. Accessories	Pole Socket, 3/8" x 16 x 1" Forged I-bolt (FIB-3/8)
Dimensions	20-15/16" W x 29-15/16" H x 16-13/16" D
Weight	85 lbs.

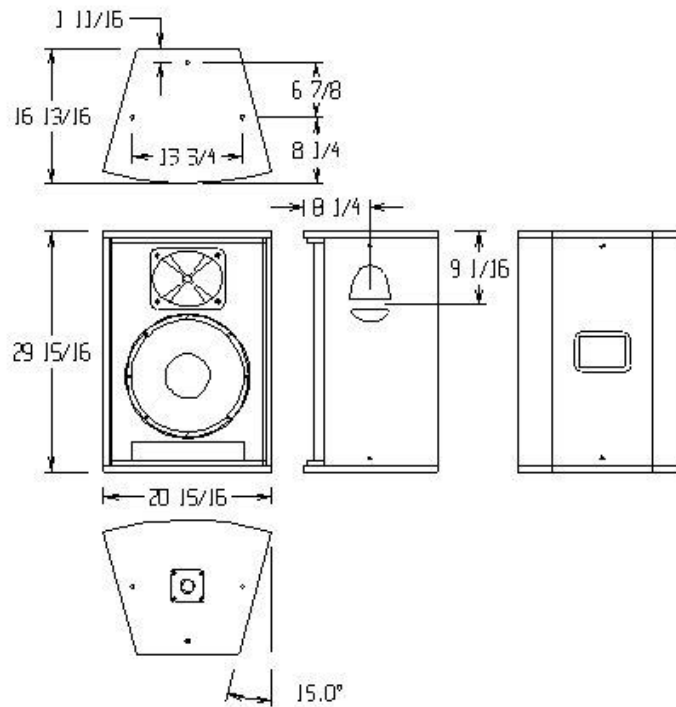

ET-152

Architectural Specifications

The loudspeaker shall be of the two-way type. The loudspeaker shall incorporate a 15" low frequency driver and a 60° (H) x 50° (V) elliptical horn coupled to a 1" exit high frequency driver. Input connection to the system shall be located on the rear of the enclosure and shall be NL4, barrier strip or ¼" jack. A 16 gauge perforated steel grill will be provided. Ease of access to the components of the system is facilitated for field serviceability. The Loudspeaker shall be the OAP Model ET-152

Flying Hardware Option

Warning!!!! Rigging and Flying of the ET-152 should be done by persons familiar with standard rigging practices. If you are not familiar please consult the factory, your Dealer, the local Stage Hands Union, or a Rigging Supply Company in your area.

The ET-152 is easily flyable using the 12 rigging points 3 on top, 3 on bottom, 2 on each side and 2 on rear of the cabinet. A 3/8" x 16 x 1" Forged I-bolt (FIB-3/8) is available for use in attaching "flying" support cables to the cabinet to the fly points.

Warranty

OAP Audio ET-152 Model Loudspeakers are guaranteed against failure due to workmanship and materials for a period of five years from the date of purchase and is limited to the original purchaser. If such failure does occur, the unit will be replaced or repaired (at the discretion of OAP Audio) without charge for labor and materials. The unit must be delivered to OAP Audio or one of its authorized service facilities prepaid. In-warranty items will be returned prepaid. Items not covered by warranty include: finish or appearance items, burned coils, or failures due to operation under other than specified conditions. This warranty also does not include any incidental or consequential damages. Repair by someone other than OAP Audio or an authorized OAP service facility will void this guarantee.

As a Research and Development Corporation, OAP Audio reserves the right to change specifications to improve performance.