



# LF-118F

## Low Frequency Loudspeaker System



### General

The LF-118F is a 1200-watt low frequency speaker systems utilizing an 18" transducer. Designed for fixed or portable use, the LF-118F should be used when additional low frequencies are needed to augment mid-range, high or full range loudspeaker systems. It can be used for sound reinforcement, music playback systems, and monitoring of musical instruments.

Structural integrity of the enclosure is insured by using 3/4" birch plywood. All connecting surfaces are glued, T-nailed, and hardwood braced. For transport durability, all edges are rounded. The steel input panel is recessed, and the handles are integral to the enclosure. The LF-118F comes with an attractive and durable textured finish. The standard color is black, with white and unfinished available. To protect the transducer, a 16-gauge epoxy coated carbon steel grill is used. An integral socket is installed in the top of the enclosure for mounting a 1.5" pole between the LF-118F and several of our T-Series of speaker systems.

### Transducer

The LF-118F uses the OAP Audio SR-1800 transducer which incorporates a 4" voice coil bonded to a glass fiber former. The frame is cast aluminum to support the massive magnet system. To insure proper cooling of the voice coil, a vented pole piece is employed. This superior transducer is combined with a fourth order enclosure for reliable low frequency reproduction.

### Input Panel Operation

The LF-118F is supplied with an input panel consisting of a barrier strip input or two parallel 15-amp 1/4" jacks. This tip is positive and the sleeve is negative.

Optional panels include, Neutrik Speakon connectors. For Neutrik Speakon connectors, pins 1 + is positive and 1 - is negative. These panels can be interchanged or removed for service in the field with only a phillips head screwdriver. To change input panels, remove the phillips head screw. Lift the panel from the enclosure and pull apart the internal connector. To install another panel, reverse the above procedure, ensure that there is color continuity on both side of the connector.

**WARRANTY:** OAP Audio loudspeaker systems are guaranteed against failure due to workmanship and materials for a period of five (5) years from date of purchase and is limited to original purchaser. If such failure does occur, unit will be replaced or repaired (at the discretion of OAP Audio) without charge for labor and materials. Unit must be delivered to OAP Audio or one of our authorized service facilities prepaid. In warranty items will be returned prepaid. Items not covered by warranty includes finish or appearance items, or failure due to operation under other than specified conditions. This warranty also does not include any incidental or consequential damages. Repair by other than OAP Audio or an authorized service facility will void this guarantee.

**ARCHITECTURAL SPECIFICATIONS:** The loudspeaker shall be of the low frequency type and be capable of usable frequency response of 45 hz. To 200 hz. The loudspeaker system shall utilize a 1200-watt 18" transducer that has a 4" voice coil, vented pole piece and cast aluminum frame. The enclosure shall be of 3/4" birch plywood and internally braced with hardwood bracing. All exposed corners shall be rounded and all

**LF-118F** All dimensions are in inches.

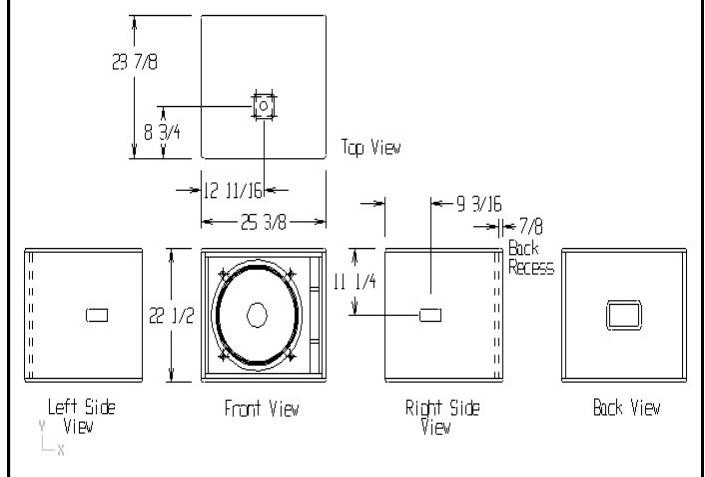

hardware recessed to be flush with the exterior of the enclosure. A 16-gauge carbon steel epoxy coated grill shall be utilized for transducer protection. An integral steel socket shall be included to facilitate and the mounting of satellite speaker systems via an optional 1.5" diameter pole. The input panel shall be removable via a field connector system to facilitate servicing and exchange of input panels. The loudspeaker system shall be the OAP Audio product model LF-118.

### LF-118F Specifications

Impedance	8 ohm nominal
Low Frequency Device	SR-1800 18" cast frame, 4" VC, vented pole piece
Frequency Response	45 Hz to 200HZ
Power Handling	1200 watts continuous program power
Sensitivity	96.75 db 1 watt @ 1 meter
Dimensions	25.375" W x 22.5" H x 23.875" D
Weight	95 lbs.
Color	Black, White and unfinished
Grill	16-gauge perforated carbon steel, epoxy coated black or white
Roadcoat (optional)	Black, Durable 100% polyurethane coating for the ultimate protective finishes

Note: As a research and development corporation, OAP Audio reserves the right to change specifications to improve performance.

Rev. E (05/13)