



TR-218

Twin-Reflex, Low Frequency System

General

The TR-218 is an 2400-watt low frequency speaker system utilizing dual 18-inch transducers. Designed for fixed or portable use, the TR-218 should be used when additional low frequencies are needed to augment mid-range, high or full-range loudspeaker systems. It can be used for sound reinforcement, music playback systems, and monitoring of musical instruments.

Two identical bass reflex systems are housed in a common enclosure. If one transducer fails, the performance of the remaining transducer is not compromised. In designs where both transducers are not acoustically isolated, problems could arise if one transducer fails. The remaining transducer is suddenly looking into a non-optimal doubled box volume. This scenario degrades performance and reduces reliability.

Structural integrity of the enclosure is insured by using 3/4" birch plywood. All connecting surfaces are glued, T-nailed, and hardwood braced. For transport durability, all edges are rounded. The steel input panel is recessed, and the handles are integral to the enclosure. The TR-218 comes with an attractive and durable textured finish. The standard color is black, with white and unfinished available. To protect the transducer, a 16-gauge epoxy coated carbon steel grill is used.

Transducer

The TR-218 uses two OAP Audio SR-1800 transducers. The SR-1800 incorporates a 4" voice coil bonded to a glass fiber former. The frame is cast aluminum to support the massive magnet system. To insure proper cooling of the voice coil, a vented pole piece is employed. This superior transducer is combined with a fourth order enclosure for reliable low frequency reproduction.

Input Panel Operation

The TR-218 is supplied with an input panel consisting of a barrier strip input or two parallel 15-amp 1/4" jacks. The tip is positive and the sleeve is negative.

Optional panels include Neutrik Speakon connectors. For Neutrik Speakon connectors, pins 1 + is positive and 1 - is negative. These panels can be interchanged or removed for service in the field with only a phillips head screwdriver. To change input panels, remove the phillips head screws. Lift the panel from the enclosure and pull apart the internal connector. To install another panel, reverse the above procedure. Be sure that there is color continuity on both sides of the connector and that the safety locks are engaged.

Optional Flyable Version Available

An optional vertical or horizontal flyable option of this speaker is available. Call the factory for details.

WARRANTY: OAP Audio loudspeaker systems are guaranteed against failure due to workmanship and materials for a period of five (5) years from date of purchase and is limited to original purchaser. If such failure does occur, unit will be replaced or repaired (at the discretion of OAP Audio) without charge for labor and materials. Unit must be delivered to OAP Audio or one of our authorized service facilities prepaid. In warranty items will be returned prepaid. Items not covered by warranty includes finish or appearance items, or failure due to operation under other than specified conditions. This warranty also does not include any incidental or consequential damages. Repair by other than OAP Audio or an authorized service facility will void this guarantee.

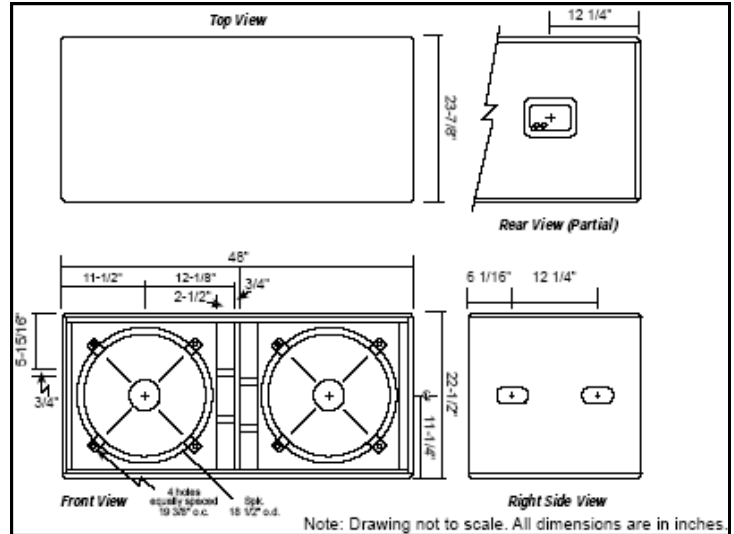

ARCHITECTURAL SPECIFICATIONS: The loudspeaker shall be of the low frequency type and be capable of usable frequency response of 45 hz to 200 hz. The loudspeaker system shall utilize two 1200-watt 18" transducers that have a 4" voice coil, vented pole piece and cast aluminum frame. Each low frequency transducer shall operate in an acoustically separate chamber and shall be housed in a common enclosure. The enclosure shall be of 3/4" birch plywood and internally braced with hardwood bracing. All exposed corners shall be rounded and all hardware recessed to be flush with the exterior of the enclosure. A 16-gauge carbon steel epoxy coated grill shall be utilized for transducer protection. The input panel shall be removable via a field connector system to facilitate servicing and exchange of input panels. The loudspeaker system shall be the OAP Audio Products model TR-218.

Specifications

Impedance	4 ohms nominal
Low Frequency Device	SR-1800 18" cast frame, 4" edgewound VC, vented pole piece and kevlar impregnated cone. 96 oz. magnet.
Frequency Response	45Hz to 200Hz
Power Handling	2400 watts continuous program power
Sensitivity	99.75db 1watt @ 1 meter
Dimensions	48"W X 22.5"H X 23.875"D
Weight	180 lbs.
Color	Black, White and unfinished
Grill	16-gauge perforated carbon steel, epoxy coated black or white
Roadcoat (optional)	Black. Durable 100% polyurethane coating for the ultimate in protective finishes.

Note: As a research and development corporation, OAP Audio reserves the right to change specifications to improve performance.

Rev. D (05/13)