



SFT-115

Low Frequency Loudspeaker System

General

The SFT-115 is a 1200-watt low frequency speaker system utilizing a 15" transducer. Designed for fixed use, the SFT-115 should be used when additional low frequencies are needed to augment mid-range, high- or full-range loudspeaker systems. It can be used for sound reinforcement, music playback systems and monitoring of musical instruments.

Structural integrity of the enclosure is insured by using 3/4" birch plywood. All connecting surfaces are glued, T-nailed, and hardwood braced. All edges are rounded. The steel input panel is recessed. The SFT-115 comes with an attractive and durable textured finish. The standard color is black, with white and unfinished available.

Transducer

The SFT-115 uses the OAP Audio SR-1596 transducer which incorporates a 4" double wound voice coil bonded to a glass fiber former. The frame is cast aluminum to support the massive magnet system. To insure proper cooling of the voice coil, a vented pole piece is employed. This superior transducer is combined with a fourth order enclosure for reliable low frequency reproduction.

Input Panel Operation

The SFT-115 is supplied with an input panel consisting of a barrier strip input or two parallel 15-amp 1/4" jacks. The tip is positive and the sleeve is negative. Optional panels include Neutrik Speakon connectors. For Neutrik Speakon connectors, pins 1 + is Positive and 1 - is negative. These panels can be interchanged or removed for service in the field with only a phillips head screwdriver. To change input panels, remove the phillips head screws. Lift the panel from the enclosure and pull apart the internal connector. To install another panel, reverse the above procedure. Be sure that there is color continuity on both sides of the connector.

WARRANTY: OAP Audio loudspeaker systems are guaranteed against failure due to workmanship and materials for a period of five (5) years from date of purchase and is limited to original purchaser. If such failure does occur, unit will be replaced or repaired (at the discretion of OAP Audio) without charge for labor and materials. Unit must be delivered to OAP Audio or one of our authorized service facilities prepaid. In warranty items will be returned prepaid. Items not covered by warranty includes finish or appearance items, or failure due to operation under other than specified conditions. This warranty also does not include any incidental or consequential damages. Repair by other than OAP Audio or an authorized service facility will void this guarantee.

ARCHITECTURAL SPECIFICATIONS: The loudspeaker shall be of the low frequency type and be capable of usable frequency response of 58 hz. to 200 hz. The loudspeaker system shall utilize a 1200-watt 15" transducer that has a 4" voice coil, vented pole piece and cast aluminum frame. The enclosure shall be of 3/4" birch plywood and internally braced with hardwood bracing. All exposed corners shall be rounded and all hardware recessed to be flush with the exterior of the enclosure. The input panel shall be removable via a field connector

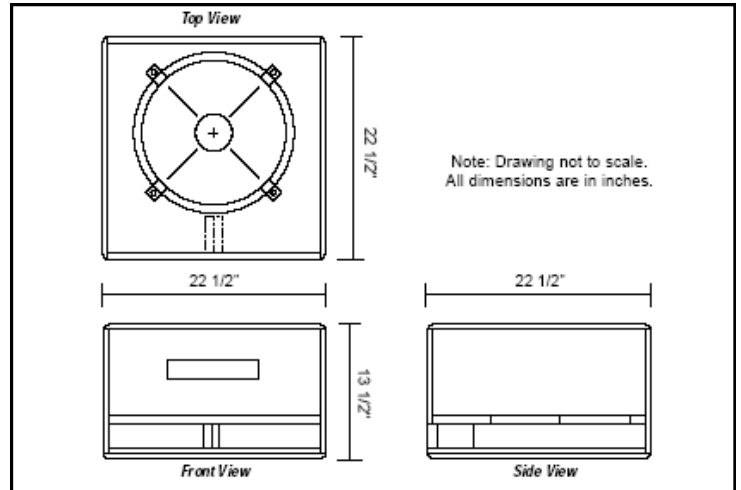

system to facilitate servicing and exchange of input panels. The loudspeaker system shall be the OAP Audio products model SFT-115.

Specifications

Impedance	8 ohms nominal
Low Frequency Device	SR-1596 15" cast frame, 4" VC and vented pole piece.
Frequency Response	58Hz to 200Hz
Power Handling	1200 watts continuous program power
Sensitivity	96.8db 1watt @ 1 meter
Dimensions	22.5"W X 22.5"D X 13.5"H
Weight	65 lbs.
Color	Black, White and unfinished
Roadcoat (optional)	Black. Durable 100% polyurea coating for the ultimate in protective finishes.

Note: As a research and development corporation, OAP Audio reserves the right to change specifications to improve performance.

Rev. E (05/13)