



Product Specification Sheet SL1-118 Flyable Single 18" Low Frequency Loudspeaker System

General

The SL1-118 is a sealed enclosure designed to provide Low Frequency support for the OAP unique "solution oriented" SL1-Series Loudspeaker Systems. The SL1-118 enclosure when matched with the SL1-200 provides for an aesthetically pleasing array in various cluster configurations. A 16 gauge steel grill or optional decorative cloth grill are available on this cabinet.

Construction

For structural integrity $\frac{3}{4}$ " birch veneer plywood is used. Top and side panels are internally reinforced with "steel" angle braces making the cabinet structurally engineered for flying. In addition all joints are reinforced with internal wood bracing both glued and cross-nailed in place.

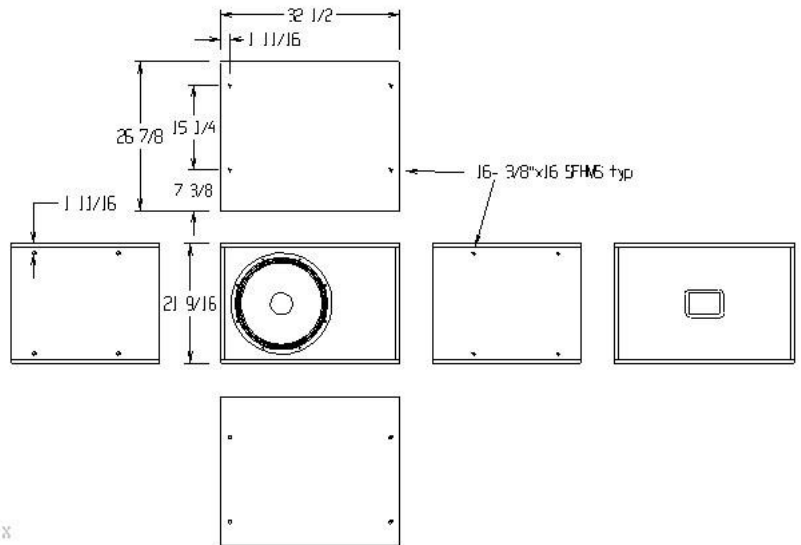

Flying Hardware Option

Warning!!!! Rigging and Flying of the SL1-118 should be done by persons familiar with standard rigging practices. If you are not familiar please consult the factory, your Dealer, the local Stage Hands Union, or a Rigging Supply Company in your area.

The SL1-118 is easily flyable using the four rigging points on the top and/or the sides of the cabinet. A $\frac{3}{8}$ " x 16 x 1" Forged I-bolt (FIB-3/8) is available for use in attaching "flying" support cables to the cabinet to the fly points.

Architectural Specifications

The loudspeaker shall be of the low frequency type and capable of usable frequency response of 35 Hz to 200 Hz. The sides of the enclosure shall be perpendicular to the top and the bottom of the enclosure. The front baffle will be parallel to the rear of the enclosure. An input plate is located at rear of the enclosure and shall incorporate a two-position barrier strip. A 16 gauge perforated steel grill or an optional fabric covered grill will be provided. Ease of access to the components of the system is facilitated for field serviceability. The Loudspeaker shall be the OAP SL1-Series model SL1-118.

NOTE: As a research and development corporation, OAP Audio reserves the right to change specifications to improve performance.

Décor Matching

The enclosure will have the finish deliverable options of "unfinished" (for future staining), "black textured enamel paint", or "white textured enamel paint". Additionally, the unit can be manufactured with a 16 gauge perforated steel grill (black or white) or optional cloth grill in black, white, wheat, or pumice.

Warranty

OAP Audio SL1-118 Model Loudspeakers are guaranteed against failure due to workmanship and materials for a period of five years from the date of purchase and is limited to the original purchaser. If such failure does occur, the unit will be replaced or repaired (at the discretion of OAP Audio) without

charge for labor and materials. The unit must be delivered to OAP Audio or one of its authorized service facilities prepaid. In-warranty items will be returned prepaid. Items not covered by warranty include: finish or appearance items, burned coils, or failures due to operation under other than specified conditions. This warranty also does not include any incidental or consequential damages. Repair by someone other than OAP Audio or an authorized OAP service facility will void this guarantee

Specifications

Impedance	8 ohm nominal
Frequency Response	35 Hz – 200 Hz
Power Handling	500 Watt Max
Sensitivity	96 dB @ 1 watt / 1 meter (2.83V @ 1m)
Dimensions	32.5" W x 21.56" H x 26.75" D
Weight	115 lbs.
Low Freq. Device	18" cast frame woofer w/ 4" voice coil
Fly Points (3/8" x 16)	16-4 on top, 4 on bottom, and 4 on sides
Cabinet Finish	Unfinished; White or Black Textured Enamel
Grill	16 Ga. Perf. Steel – White or Black; Cloth option
Input	White, Black, Wheat, Pumice
	2 position Terminal Strip